



Arkbird Wireless Head Tracker

Arkbird Wireless Head Tracker maybe the first wireless head tracker in FPV field, Camera on plane is moveable with the help of this wireless head tracker, a wonderful FPV experience you deserve.

Feature:

- Providing an Omni-directional FPV view;
- Variety connection methods available;
- Precisely calculation and movement;
- No wires, neat performance and move freely;
- Good compatibility, work with most signals and UHF.

Attention:

Please read manual carefully before using this product.

Checking all details including connection carefully before powering is very important. Any wrong connections may result in permanent damages. The receiving module should be put ahead of transmitter module in order to ensure good receive performance of wireless signal.

Receiving module of Arkbird Wireless Head Tracker has PPM in and PPM out. Meanwhile it is also work with 2 PWM out:

When you using PPM in and PPM put, the roll and pitch control value will be imposed to Channel 9 and Channel 10 of your radio PPM.

When you using two PWM output, head tracker is able to give a pitch and roll control of your servo. (You can use it directly on PWM mode of any 433 UHF systems)

Transmitter Module

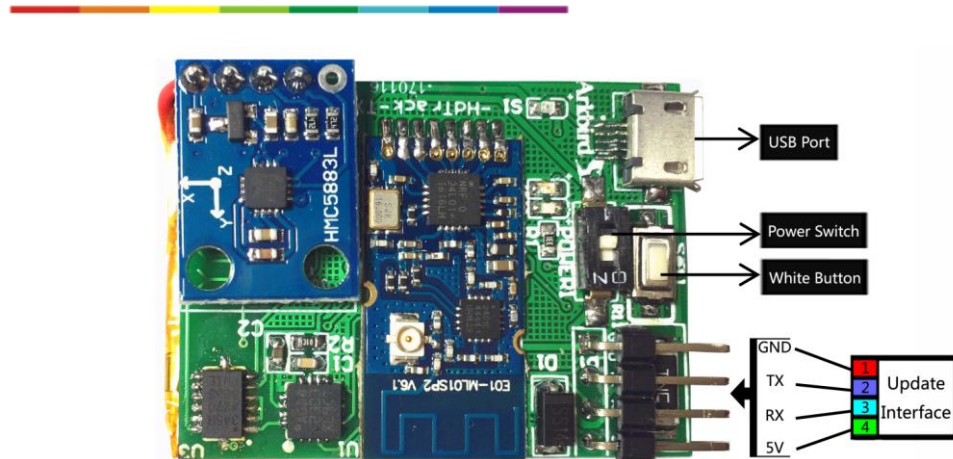

1. Assembly method of Transmitter Module (Recommended)

Assemble the transmitter module on the front side as shown in the following picture:



2. Guide for using transmitter module

(1) Calibrating sensor:

Step 1, switching ON the transmitter module, you will see the Yellow LED light and Blue LED keep lighting in about 3 seconds, which means the transmitter is in pairing frequency status ;

Step 2, when the frequency has been paired, please let the USB port is pointing left side, then pressing the white function button until Yellow LED and Blue LED keep flight, and no press the white button, Yellow LED will be turned off..

Step 3, horizontally spin the transmitter module for three circles, then LED Blue will be turn off and LED Yellow will be turn on

Step 4, vertically spin the transmitter module for three circles, then LED yellow will be turn off. Thus, calibration finished.

Video link: <https://www.youtube.com/watch?v=VDNjH6xjF4A>

(2) Restore default settings:

It is important for you to pressing the white button to restore default setting when you use transmitter. You can restore default setting when you are using head tracker, if so, current direction will be set as start position.

Receiving module

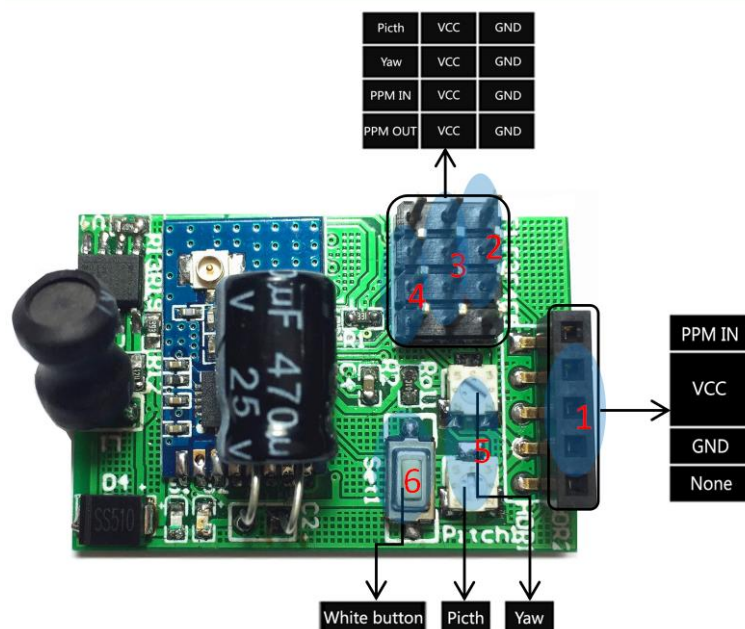

1. Receiving Module Definition:

(1) Port 1: Any radios which have PPM port such as futaba, frsky, x9d can be directly connected. Definition of each port (See above picture): PPM IN, 12V input, 12input, GND and blank. (PS: The two 12V inputs are individually powered)

(2) GND;

(3) VCC (8V<VCC<20V) for power supply;

(4) As it shown in the above picture, definition of Port 4 is Pitch PWM OUT, Roll PWM OUT, Radio PPM IN (It shows RX when firmware updating), Radio control PPM OUT (It shows RX when firmware updating.)

(5) PWM value spinner. Starting from the top as shown above, definition of Port 5 are Roll Spinner and Pitch Spinner.

(6) Port 6 is the function button, which will also be used when firmware updating.

2. Wiring instructions:

Connection Method A: PPM transit connection:

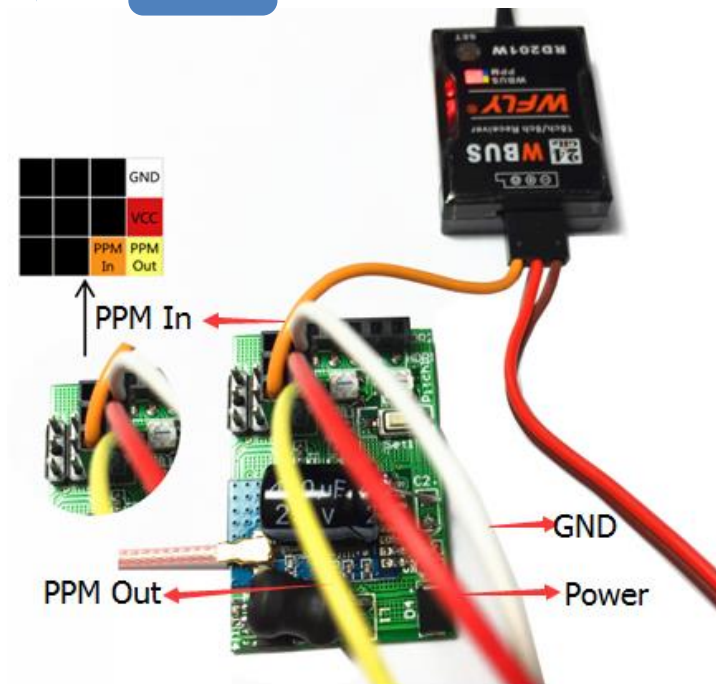
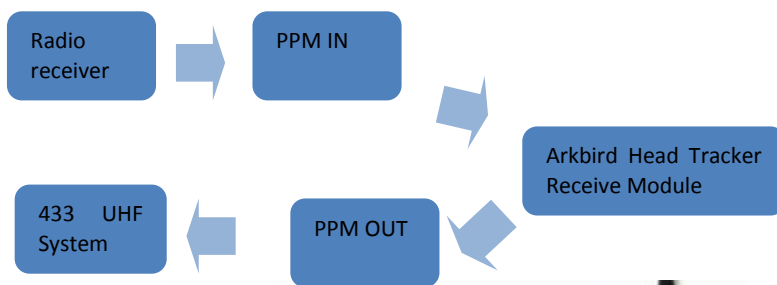

External 433 UHF will supply power for receiving module and radio receiver. The radio PPM signal is connected with PPM input of Arkbird wireless head tracker receiving module; PPM

output of Arkbird wireless head tracker receiving module is connected with PPM input of 433 UHF.

Connection Method B: PPM directly connection (One cable connection)

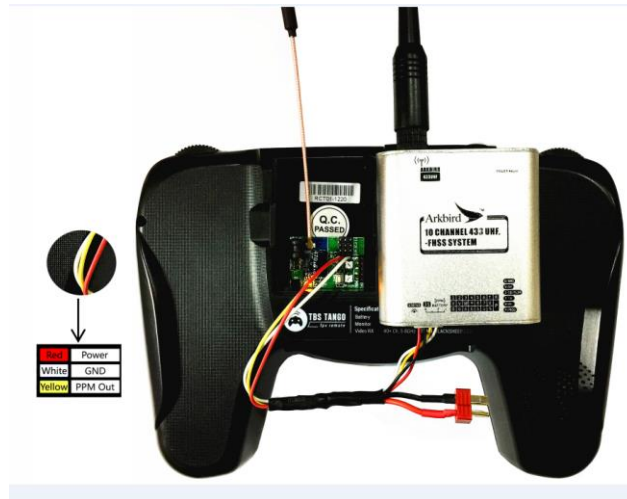

In PPM mode, Radio (Plug T not connected) will supply power for head tracker receiving module and 433 UHF transmitter. PPM signal from radio will be sent to receiving module of head tracker, which will impose pitch and roll control values to PPM signal Channel 9 and Channel 10. The signal will be sent to 433 UHF.

Connection Method C: PWM directly connecting

Individually connect Channel 1 to Channel 8 of radio receiver with corresponding Channel 1 to Channel 8 of 433 UHF transmitter; connecting PWM PITCH output of head tracker receiver module with Channel 9 of 433 UHF transmitter; connecting YAW output of head tracker receiver module with Channel 10 of 433 UHF transmitter;

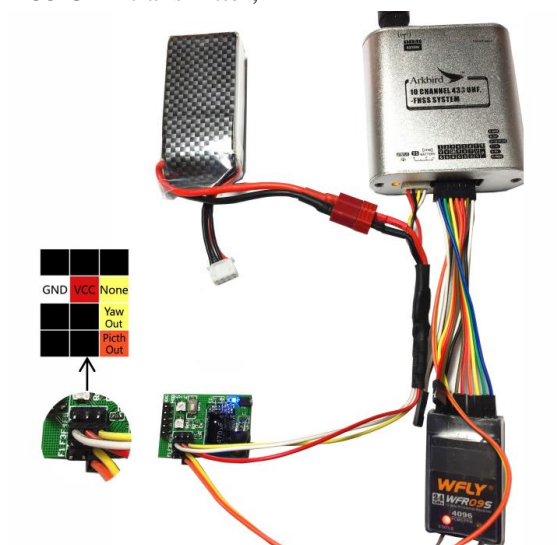

Connection Method D: Connect with Radio Train Connector

For any radios support training mode, which is able to connect PPM output signal of head tracker receive module with radio's training port. Please set radio's channel 9 and channel 10 as training mode according to radio's manual, thus, signal of head tracker can be sent via radio directly.

3. Guide for operating receiving module

(1) Frequency alignment

Frequency alignment is needed when you firstly use this device or update firmware. **Yellow LED light and Blue LED light will interactively flash** when firstly power it, which shows receive module is in frequency status, then turn on the transmitter module, which will be automatically pair frequency.

Press the white button for 11 seconds or more when you want to fair frequency again. Keep pressing white button until **Yellow LED light and Blue LED light interactively flash**, which shows receive module is in frequency status, then turn on the transmitter module, and receive module will be automatically pair frequency and save data.

(2) Failsafe Setting

Pressing the white button for 8 seconds and do not release button until **Yellow LED light and Blue LED light interactively flash**. If the receive module lose signal, it will automatically enter into failsafe mode..

In failsafe mode, only PPM signal from Channel 9 and Channel 10 will be interfered, others do not have any influence. (Arkbird head tracker only uses these two channels.)

(3) Trim servo value

Turn Pitch and Roll (Yaw) potentiometer clockwise or counterclockwise to set or trim value of servo until get satisfactory status.

Attention: Do not turn the potentiometer with extreme force. Not allowed to turn the potentiometer when it is stuck to protect potentiometer.

III. Introduction of working status of transmitter module and receiver module



1. Introduction of working status of transmitter module

- **Frequency alignment status:** when the module is powered on, **Yellow LED light and Blue LED light** will keep lighting on about 3 seconds. Then frequency will be automatically paired.
- **Normal working status:** when the frequency alignment is done, **Yellow LED light will turn off and Blue LED light will double flash.**

- **Power shortage status:** when the module is lack of enough power, **Blue LED will turn off and Yellow LED light will flash.** Transmitter module will stop working and waiting for being charged.
- **Charging mode status:** when the transmitter module is lack of power, USB data cable could be used for charging. In the charging mode, **Red LED light will keep on** until it is fully charged. **Then Red LED will turn off which means full of power.**

2. Introduction of working status of receiving module:

- **Failsafe mode status:** if the transmitter module is not powered on or lose signal, the receiving module will be automatically entry into failsafe mode. In this mode, **Yellow LED and Blue LED will slowly and interactively flash.**
- **No PPM signal input status:** **Blue LED light double flashing and Yellow LED light flashing successively which** indicates both transmitter module and receive module are in working status, while the PPM signal input is abnormal. Checking the PPM signal wire connection of receive module is needed.
- **Normal working condition:** when **Blue LED light flashing 1 second per circle and Yellow LED light flashing successively** indicates head tracker is normal working condition.